



all you need is a little imagination



Touchdry with polished chrome nozzle and button TOUCHDRY-PC



Autobeam with silver gloss nozzle AUTOBEAM

Evolution favours innovation

In Darwinian terms the Australian made Autobeam and Touchdry range of hand dryers by JD MacDonald is a quantum leap. The original 1000 series range of hand dryers is today, one of the most visible hand dryers in Australia. Renowned for its robust design, and anti-vandalism features, the original 1000 series set a new benchmark in reliability. What standards had been set by the original 1000 series have been exceeded by the new range of Autobeam and Touchdry hand dryers.

ACCLIMATISATION

Drying time, airflow and heat settings all play a part in creating a comfortable experience for hand dryer users. This range has seen improvement in each of these areas. Recent innovations in computer-aided design and development have allowed

nozzle efficiencies to be improved. When combined with improved air velocity, (due to a more efficient motor) and a more comfortable heat setting, the hand dryers set new standards in drying time and noise levels, all of which improve user comfort.

VARIATION UNDER DOMESTICATION

The Touchdry range of hand dryers feature a solid touch button mechanism, which improves feedback to the user and there is no confusion if the hand dryer has been manually activated.



Autobeam with full satin chrome cover and nozzle AUTOBEAM-SCCH



Autobeam with polished chrome nozzle AUTOBEAM-PC



Autobeam with satin chrome nozzle AUTOBEAM-SC

The Autobeam range of hand dryers features improved sensor accuracy, making it easier to activate.

All models in the range feature an improved tamper-proof, locking mechanism.

When combined with a heavy duty, marine grade cast aluminium case, this locking further enhances the vandal proofing of the entire range.

NATURAL SELECTION

Robust, simple design and quality componentry has ensured the survival of the 1000 series in one of the most hostile environments on the planet. . .

public bathrooms. So why not select the Autobeam & Touchdry hand dryers for your next project that will outlast and out live the rest... naturally.

VARIATION AND SPECIALISATION

In nature, evolution leads to variation and specialisation. The same can be true of design evolution. The Autobeam and Touchdry range features a choice of nozzle finishes including 'titanium look' satin chrome, polished chrome, and painted grey. The variety of nozzle finishes allow architects and designers more opportunity to match finishes to their overall design for

commercial bathrooms.

Unique to this range is an all chrome model. This striking looking automatic hand dryer, is a dramatic deviation from the otherwise understated 1000 series range. This variation allows design and architects access to a hand dryer that can easily serve as the focal point for the bathroom.



Autobeam with full polished chrome cover and nozzle AUTOBEAM-PCCH

AUTOBEAM & TOUCHDRY

Features:

- Heavy duty cast aluminium hand dryer
- Solid touch button operation with optional swivel nozzle
- Large fan and motor assembly provides a high performance dryer designed for high traffic areas and heavy use
- Easy installation with tamper-proof locking
- Made in Australia

Installation options:

- Electrical connection by cord and plug (as supplied)
- Can be direct wired by an electrician

Specifications:

- Electrical AC, 230–240V 50Hz, 10A
- Motor 90 Watt, 5000 RPM
- Element 2310 Watt protected by thermal cut-out
- Air Velocity 18.5m/s
- Noise level 76dB (A)
- Gross weight 5.4kg
- Shipping 6kg
- Certificate of Suitability No. Q070423

- Electrical Safety Requirement AS/NZS 60335.2.23:2004
- Protection Category IPX3

Autobeam Finish:

- Autobeam with silver gloss nozzle, model no. AUTOBEAM
- Autobeam with satin chrome nozzle, model no. AUTOBEAM-SC
- Autobeam with polished chrome nozzle, model no. AUTOBEAM-PC
- Autobeam with full polished chrome cover and nozzle, model no. AUTOBEAM-PCCH
- Autobeam with full satin chrome cover and nozzle, model no. AUTOBEAM-SCCH

Touchdry Finish:

- Touchdry with silver gloss nozzle and button, model no. TOUCHDRY
- Touchdry with satin chrome nozzle and button, model no. TOUCHDRY-SC
- Touchdry with polished chrome nozzle and button, model no. TOUCHDRY-PC

Options:

- Designer colours for quantity purchases

*Recommended installation height:

- Men's washroom 1200mm
- Women's washroom 1150mm
- Children's washroom ages 11-15 1110mm
- Children's washroom ages 5-10 850mm
- Disabled person's washroom 1000mm

Warranty

JD MacDonald Touchdry and Autobeam hand dryers are guaranteed against defective materials and faulty workmanship for 10 years from date of purchase, subject to being installed and maintained in accordance with the Installation and Operating Instructions supplied with the hand dryer.

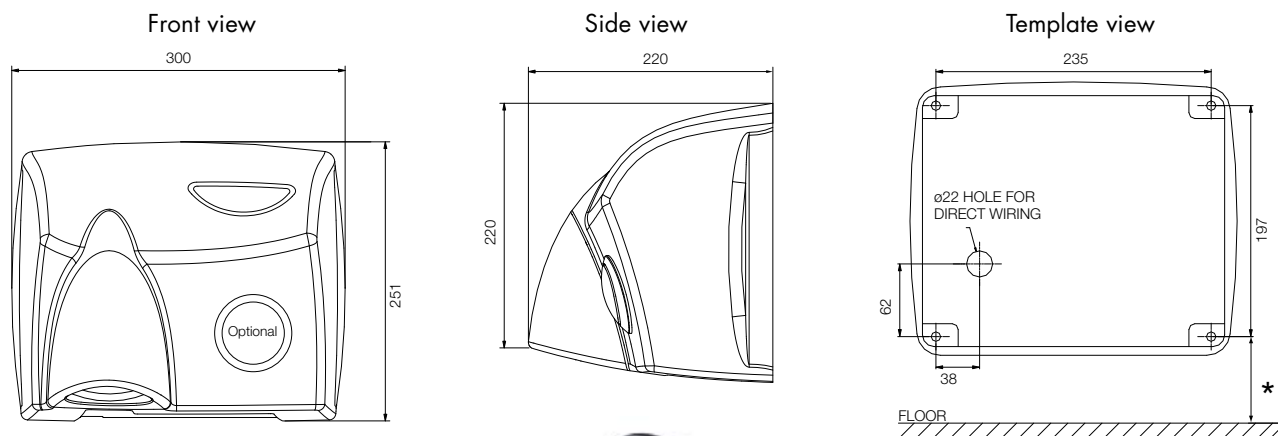

Solid touch button



jdmacdonald.com.au

Freecall 1800 023 441 or phone your nearest JD MacDonald Sales Office

Adelaide (08) 8168 2222 Brisbane (07) 3205 3166 Melbourne (03) 9271 6400 Perth (08) 9271 8455 Sydney (02) 9756 1622

A Division of MacDonald Johnston Pty Ltd 65–73 Nantilla Road, Clayton North, Victoria 3168 Tel (03) 9271 6400 Fax (03) 9271 6485

JD MacDonald reserves the right to, and does from time to time, make changes and improvements in design and dimensions.

The photographs & line drawings of the products in this catalogue are representational only. All dimensions are in millimetres.

