



**Step 1**  
Unlock the cover and open.  
Remove the front cover.



 Hinges are strong enough, but a duty of care is needed when removing cover.

**Step 2**  
 Carefully remove optical sensor lead from printed circuit board prior to pulling grill clear. Remove the grill by unscrewing four, 1-1/4" screws.



**Step 3**  
Remove the housing by carefully swinging away from steel chassis at the lower edge and slide it upwards until it is clear of the base unit.



**Step 4**  
Survey the intended mounting location to ensure a power source is available.

The Hand Dryer SHOULD NOT be mounted in close proximity of any reflective surface. (300mm).

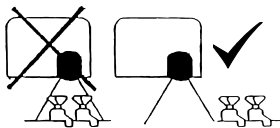

**Note:** Installing the Hand Dryer above washbasins or bench tops may cause the dryer to switch on automatically. If this is the case, the beam sensitivity distance will be automatically reset after approximately 45 seconds.

**Step 5**  
Securely mount Hand Dryer base to wall using the appropriate hardware (not included with product). See below:

- Stud Wall** - use 50mm long wood screws
- Brick Wall** - use 6mm x 50mm expanding screw plugs
- Plaster Wall** - use 6mm toggle bolts

 **Minimum of four mounting screws.**

Ideally the surface to mount the Hand Dryer should be flat. M8 washers may be used as spacers if necessary to align chassis. Do not over tighten mounting hardware.



**Step 6**  
Use the attached cable to make the required power connections. The connection of the wiring must be made in accordance with the wiring standards and must include means for disconnection, AS/NZS 3000.

If the supply cord is damaged, it must be replaced by the manufacturer, its service agent or similarly qualified persons in order to avoid a hazard.

 Do not reverse the connections as it may damage the printed circuit board. (No warranty shall apply)  
Do not switch power on until casing has been installed unless under strict test control conditions.

**Note:** Active and neutral power circuits become exposed without the cover fitted.

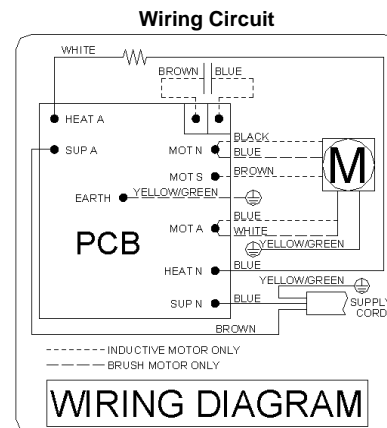

**Step 7**  
Fit the housing to steel chassis.  
Carefully connect optical sensor lead to printed circuit board and fix grill to housing, ensuring that clips are located securely behind housing and chassis locations.  
Fit the front cover to housing, fill tray with paper towels and lock unit.

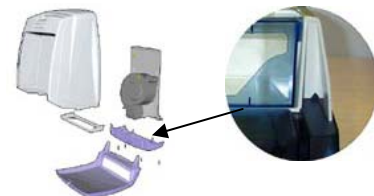

**Step 8**  
Test unit  
Switch on power and check function of the unit.  
Place hand under sensor and unit should operate continuously and then for a further 5 seconds once hands are removed from the operating area.

**Note:** It is recommended that these units should not be directly/indirectly hosed down.

This appliance is not intended for use by persons (including children) with reduced physical, sensory or mental capabilities, or lack of experience and knowledge, unless they have been given supervision or instruction concerning use of the appliance by a person responsible for their safety. Children should be supervised to ensure that they do not play with the appliance.

 All JD MacDonald disabled compliant products when installed must be in accordance with AS1428 to ensure the specified product is complying with all washroom specification requirements.

# Pronto 12 Month Warranty

---

## JD MacDonald Warranty for Australia

JD MacDonald expressly warrants this product against defects caused by faulty workmanship for a period of 12 months from the date of purchase providing the product is installed and maintained in accordance with JD MacDonald's instructions.

During the warranty period, JD MacDonald will repair or replace, at its option, the complete product or components that fail due to faulty workmanship or components.

### Terms and Conditions

The warranty period commences on the date of original purchase of the equipment. Evidence of this date of original purchase must be provided when claiming repairs under warranty. It is recommended you retain all invoices or receipts in a safe place.

In the event of a product being replaced during the warranty period, the warranty on the replacement will then expire at the original date, i.e. 12 months from the original purchase date.

The warranty excludes defects caused by the product not being used in accordance with instructions, accidental damage, misuse or being tampered with by unauthorised persons.

This warranty is subject to due compliance by the original purchaser with all directions and conditions set out in the Installation and Operating Instructions.

JD MacDonald will provide whenever possible on-site service in areas covered by nominated agents. JD MacDonald will only be responsible for labour charges where this is provided by JD MacDonald authorised service agents. If on-site service is not provided due to distance or is excluded from this warranty it will be the owners responsibility, at their expense, to return the product, suitably packaged to JD MacDonald's service provider or state office.

Apart from this express warranty the only conditions, warranties, liabilities to compensate or indemnify representations and statements which are binding upon JD MacDonald in relation to its supply of goods are those required by law (including the Trade Practices Act 1974) to be binding upon it and otherwise all conditions and warranties whether express or implied by law and all other representations, statements and obligations which would be binding upon JD MacDonald are hereby excluded and negated.

Should a failure or fault occur please contact our Customer Service Department on **1800 023 441** and advise the model and serial number and mode of failure. Customer Service will then provide authorisation for its service agent to repair or replace the unit in accordance with the process outlined above. Note proof of purchase in the form of an invoice or purchase receipt must accompany any claim.

Except to the extent provided for above, JD MacDonald excludes its liability (including liability in negligence) to any person for any loss or damage, consequential or otherwise howsoever suffered or incurred by any such person caused by or resulting directly or indirectly from the goods or from any failure breakdown defect or deficiency of whatsoever nature and kind or in the goods.

### Maintenance Note

To ensure your Hand Dryer is operating at its maximum performance whilst also maintaining its life, the following cleaning instructions should be carried out at least once per year or six monthly for heavy work areas.



Before commencing any maintenance activities the power source must be disconnected from the dryer.

- Remove case and remove dust from all parts using a small brush or compressed air.
- Check all wiring connections are secure.
- Replace the case, reconnect power and check operation.