



**FEATURES**

Combination of an electric automatic hand dryer and a paper towel dispenser. A 200 series dirak lock with a hooked cam with high strength hinge mechanism secures the high impact polycarbonate cover incorporating a 2 pack paper towel capacity.

**INSTALLATION OPTIONS**

Electrical connection by cord & plug (as supplied). Can be direct wired by an electrician.

**SPECIFICATION**

- High impact polycarbonate
- Electrical: AC, 230-240V. Supply 50Hz, 7A
- Motor: 65 Watt, 2500 RPM
- Element: 1600 Watt protected by thermal cut-out
- Air Velocity: 16.2m/s at nozzle outlet
- Noise Level: 65dB (A)
- Top mounting holes 1700mm from floor
- Weight: Gross 5.75kg
- Certificate of Suitability No: Q070748
- Electrical Safety Requirement: AS/NZS 60335.2.23:2004

**FINISH**

Cover/outlet: white etched opaque. Main body: high gloss white.

**RECOMMENDED INSTALLATION HEIGHT**

Men's washroom	1200mm
Women's washroom	1150mm
Children's washroom ages 11-15	1110mm
Children's washroom ages 5-10	850mm
Disabled person's washroom	1000mm 

**WARRANTY**

JD MacDonald Pronto hand dryer is guaranteed against defective materials and faulty workmanship for 12 months from date of purchase, subject to being installed and maintained in accordance with the Installation and Operating Instructions supplied with the hand dryer.

**Pronto** shall be Model No. PRONTO-FC as manufactured by JD MacDonald.

 All JD MacDonald disabled compliant products when installed must be in accordance with AS1428 to ensure the specified product is complying with all washroom specification requirements.

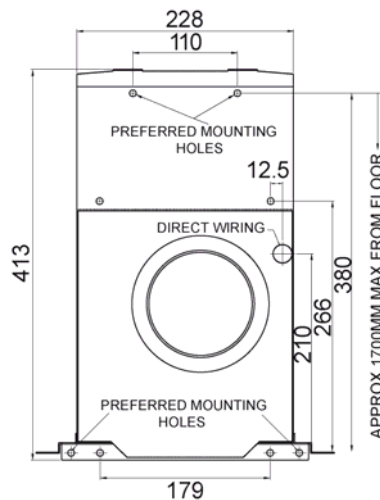
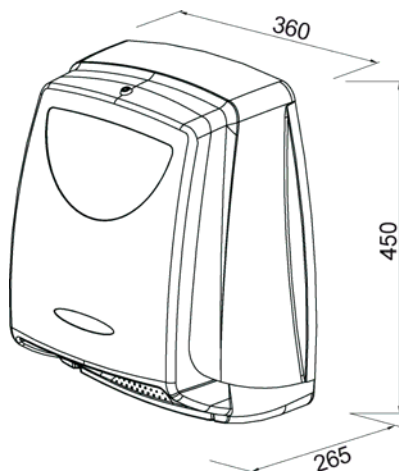

JD MacDonald reserves the right to, and does from time to time, make changes and improvements in design and dimensions. The photographs and line drawings of the products in this flyer are representational only. All dimensions are in millimetres.