



FEATURES

- Easy and fast installation into new or existing sinks
- Powerful Permanent Magnet Motor 2600RPM
- Unique Torque Master Grinding System
- Stainless Steel Balanced Armature Shaft
- Anti-jam Stainless Steel Impellers
- Only disposer treated with Bio Shield Antimicrobial Protection
- Removable Splash Guard for easy cleaning & replacement
- Corrosion Proof Grinding Chamber

SPECIFICATION

- Horsepower: 1/2HP
- Motor speed: 2600 RPM
- Voltage: 220-240V
- AMPS: 2.25
- Cycles: 50/60
- Motor type: Permanent magnet
- Stopper: ABS
- Appliance protector: Manual reset
- Sound shell: Partial
- Individual shipping weight: 4.4kg

MATERIALS

- Splash guard: Santoprene
- Drain outlet: Polycarbonate 940
- Grind ring: Stainless steel
- Swivel impellers: Stainless steel
- Balanced turntable: Stainless steel
- Balanced armature shaft: Stainless steel
- Hopper: Polycarbonate 940
- Drain housing: Phenolic EA-5551J
- Sink flange: Polycarbonate 940
- Bearings: sleeve permanently lubricated

WARRANTY

JD MacDonald WasteMaid Model 158 has a Lifetime corrosion warranty and a 4 year replacement warranty.

OPTIONAL ACCESSORIES

- Wireless control switch
- Air switch

WasteMaid 158 shall be Model No. 158 as supplied by JD MacDonald.

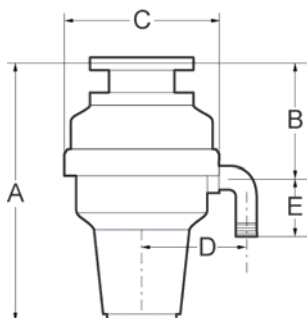

	Model 058	Model 128	Model 158	Model 358	Model 458
A	355mm	381mm	355mm	379mm	406mm
B	165mm	184mm	165mm	184mm	184mm
C	121mm	187mm	121mm	215mm	215mm
D	135mm	135mm	135mm	142mm	142mm
E	70mm	70mm	70mm	70mm	70mm